

Semi-trailer: SR 3500

The SR3500 semi-trailer is a versatile platform designed to be easily adapted to a wide range of applications, specially telecommunication.

Inertial brake system and equalized leaf spring suspension.

Towing vehicle		Light truck, towing capacity min , with 50mm ball hitch or Pintle hook
Hitch weight	kg	up to 350
Chassis structure		Welded Steel "U" beam profiles
Approximated weight	kg	800
Max load	kg	2700
Max total gross weight	kg	3500 (SAE Class 4)
Brakes		Inertial and hand-brake, drums on two wheels
Axle		2 with equalized leaf spring suspension
Painting		Two-layer, according to the Petrobrás Standard N-1202F / N-2677
Optional		Leveling jacks
Dimensions	m	Platform: 3,5x1,75 Total: 4,86x2,21 Platform height: 0,73
Part #		28240

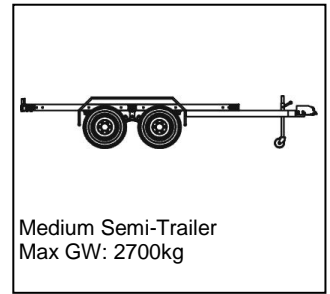

RF COM is member of the National Association of Trailer Manufacturers (USA), and follows its design and manufacturing recommendations.



Sistema com mastro 18,3m e BTS Nokia 2G+3G

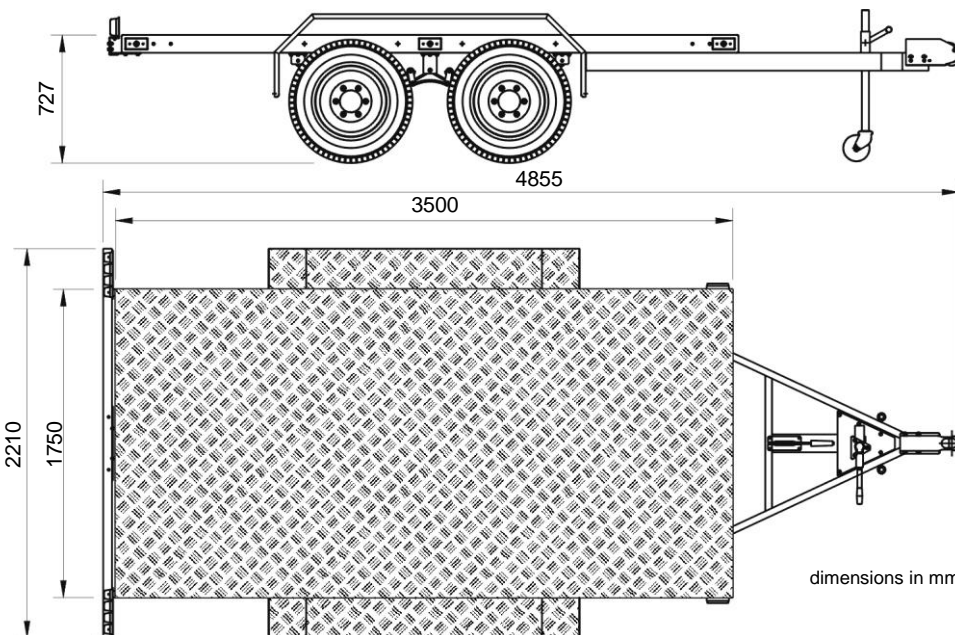

Contact us about your application. RF COM can design and manufacture any necessary support or modifications for the integration of your equipment to the SR3500.